

T2 Armor Enclosure for iPad

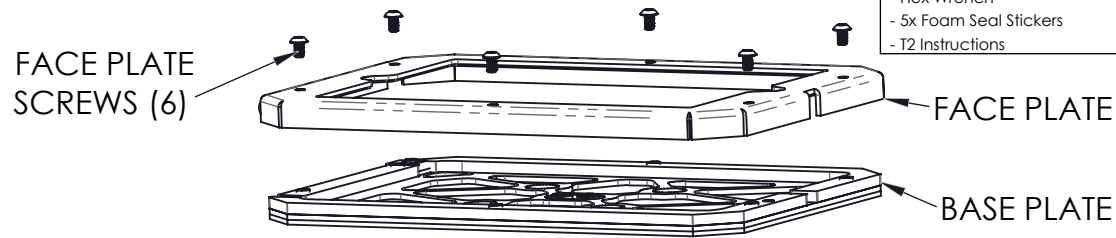

What's Included:

- T2 Armor Enclosure
- Hex Wrench
- 5x Foam Seal Stickers
- T2 Instructions

Step 1: Remove the face plate screws using the provided hex wrench.

Step 2: Remove the face plate.

Note:

iPad Foamseal stickers can be placed for added weather protection.

Step 3: Place the iPad centered in the base plate.

Note:

iPad Mini 1,2,3 requires foam spacers to be installed and insert foam removed.

iPad Mini 4, iPad Air 2, and iPad Pro 9.7 requires insert foam to be installed under tablet.

Step 4: Align the face plate onto the base plate.

Step 5: Thread the face plate screws in by hand.

Step 6: Torque the screws using the provided hex wrench in the pattern shown.

Note:

Loosen screw #1 if Power Button does not function.

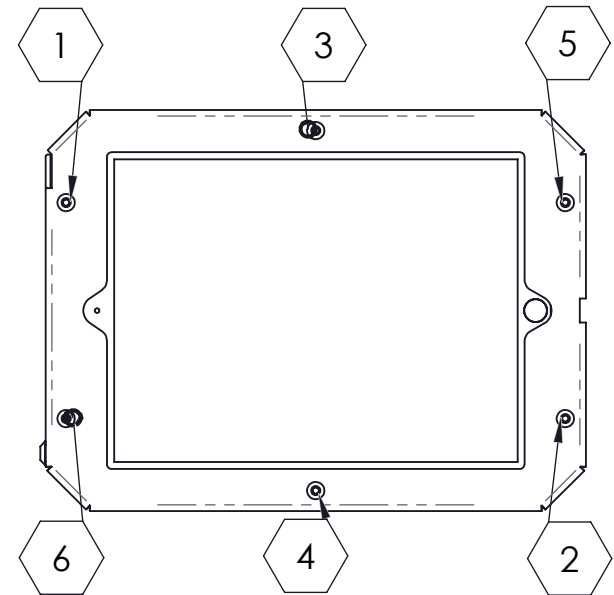

T2 Armor Enclosure for iPad

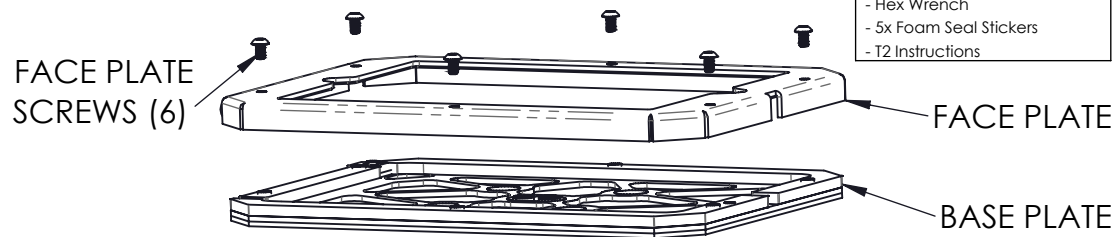

What's Included:

- T2 Armor Enclosure
- Hex Wrench
- 5x Foam Seal Stickers
- T2 Instructions

Step 1: Remove the face plate screws using the provided hex wrench.

Step 2: Remove the face plate.

Note:

iPad Foamseal stickers can be placed for added weather protection.

Step 3: Place the iPad centered in the base plate.

Note:

iPad Mini 1,2,3 requires foam spacers to be installed and insert foam removed.

iPad Mini 4, iPad Air 2, and iPad Pro 9.7 requires insert foam to be installed under tablet.

Step 4: Align the face plate onto the base plate.

Step 5: Thread the face plate screws in by hand.

Step 6: Torque the screws using the provided hex wrench in the pattern shown.

Note:

Loosen screw #1 if Power Button does not function.

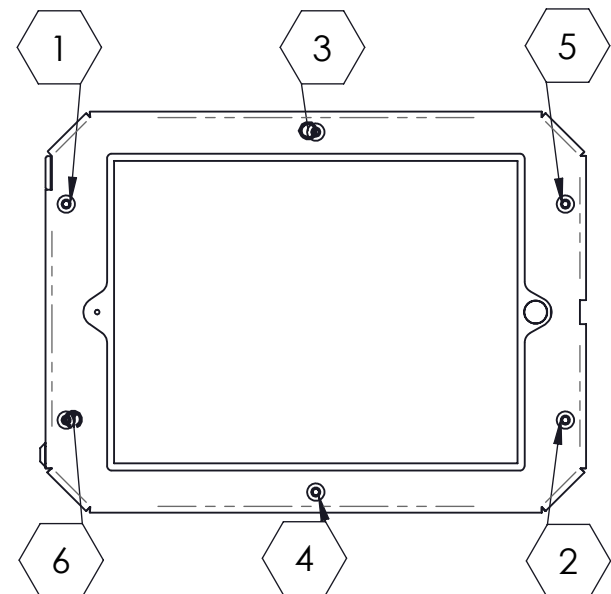

WARRANTY

For assistance, please contact us directly at:

MOB ARMOR

www.mobarmor.com

2320 Thompson Way, Suite L

Santa Maria, CA 93455

Customer Service: (805) 214-1815

Safety Guidelines: Stop the vehicle in a safe location or have a passenger use the system. Safely operate the vehicle, obey all laws and regulations, and use good judgment at all times. Note: User assumes sole responsibility for and all risk in using this system. General Guidelines: Install the device in a non-obstructive, safe location within the vehicle cab. Avoid obstructing the following: Vehicle operation, Visibility through windows, Safe entry or exit, Safety devices such as air bags. Firmly secure the device to stay in place despite vibrations, shocks bumps, or vehicle accidents. Do not use this system or any computer system while operating a motor vehicle. Mob Armor is not responsible or liable for personal and or property damage.

What does your 100% Satisfaction Guarantee mean?

Our 100% Satisfaction Guarantee means we guarantee you will be satisfied with your Mob Armor Product, or we will refund your money. If you are unsatisfied with your product at any time within 30 days of your purchase, you can return it to us for a full refund, no questions asked. You pay shipping back to us. We do not refund any shipping cost.

What warranty does Mob Armor offer?

The Mob Armor Warranty covers all defects in workmanship or materials of our products for up to one year. This warranty applies only to the original purchaser at retail and may not be transferred. This warranty only covers defects arising under normal usage and does not cover any malfunction, damage or failure due to accident, misuse, abuse, neglect, alteration, modification or repair by other than an authorized service center for Mob Armor products. Scratching of the powder-coated surface, anodizing or plastic constitutes normal wear and is not covered under warranty.

WARRANTY

For assistance, please contact us directly at:

MOB ARMOR

www.mobarmor.com

2320 Thompson Way, Suite L

Santa Maria, CA 93455

Customer Service: (805) 214-1815

Safety Guidelines: Stop the vehicle in a safe location or have a passenger use the system. Safely operate the vehicle, obey all laws and regulations, and use good judgment at all times. Note: User assumes sole responsibility for and all risk in using this system. General Guidelines: Install the device in a non-obstructive, safe location within the vehicle cab. Avoid obstructing the following: Vehicle operation, Visibility through windows, Safe entry or exit, Safety devices such as air bags. Firmly secure the device to stay in place despite vibrations, shocks bumps, or vehicle accidents. Do not use this system or any computer system while operating a motor vehicle. Mob Armor is not responsible or liable for personal and or property damage.

What does your 100% Satisfaction Guarantee mean?

Our 100% Satisfaction Guarantee means we guarantee you will be satisfied with your Mob Armor Product, or we will refund your money. If you are unsatisfied with your product at any time within 30 days of your purchase, you can return it to us for a full refund, no questions asked. You pay shipping back to us. We do not refund any shipping cost.

What warranty does Mob Armor offer?

The Mob Armor Warranty covers all defects in workmanship or materials of our products for up to one year. This warranty applies only to the original purchaser at retail and may not be transferred. This warranty only covers defects arising under normal usage and does not cover any malfunction, damage or failure due to accident, misuse, abuse, neglect, alteration, modification or repair by other than an authorized service center for Mob Armor products. Scratching of the powder-coated surface, anodizing or plastic constitutes normal wear and is not covered under warranty.